

*Installation Guide  
for*



***AL400ULACM***  
***Access Power Controller  
with Power Supply***

*UL Listed, Multi-Agency Approved*

**Rev. 052201**



# AL400ULACM Access Power Controller with Power Supply

## Overview:

The AL400ULACM distributes and routes power to access control systems and accessories. It will convert a 115 VAC 50/60Hz input into eight (8) independently controlled fuse protected class 2 power limited 12VDC or 24VDC outputs. These outputs can also be configured as dry form "C" contacts. Outputs are activated by an open collector sink or normally open (NO) dry trigger input from an Access Control System, Card Reader, Keypad, Push Button, PIR, etc. The unit will route power to a variety of access control hardware devices including: Mag Locks, Electric Strikes, Magnetic Door Holders, etc. Outputs will operate in both fail-safe and/or fail-secure modes. The FACP Interface enables Emergency Egress, Alarm Monitoring, or may be used to trigger other auxiliary devices. The fire alarm disconnect function can be configured for the following modes; a) Eight (8) outputs affected. b) Four (4) outputs affected and four (4) outputs unaffected (50/50 mode).

## Specifications:

- UL Listed Access Control Systems and Burglar Alarm Systems (UL294 and UL603).
  - MEA approved - NYC Dept. of Buildings.
  - CSFM approved - California State Fire Marshal.
  - Input 115VAC 50/60Hz, 1.9 amps.
  - 4 amps continuous supply current at 12VDC.
  - 3 amps continuous supply current at 24VDC.
  - Field selectable 12VDC or 24VDC operation.
  - Power supply input options:
    - a) One (1) common power input for ACM8 and lock power (factory installed).
    - b) Two (2) isolated power inputs (external power supply is required).  
(for this option output current is determined by the power supply connected, not to exceed a maximum of 10 amp total).
  - Eight (8) Access Control System trigger inputs.
    - Input options:
      - a) Eight (8) normally open (NO) inputs.
      - b) Eight (8) open collector inputs.
      - c) Any combination of the above.
  - Eight (8) independently controlled outputs.
    - Output options:
      - a) Eight (8) Fail-Safe and/or Fail-Secure power outputs.
      - b) Eight (8) form "C" 5 amp rated relay outputs.
      - c) Any combination of the above.
  - Eight (8) auxiliary power outputs (unswitched).  
(class 2 power limited fused outputs are rated 3.5 amp).
  - Main fuse is rated at 10 amp.
  - Red LEDs indicate outputs are triggered (relays energized).
  - Fire Alarm disconnect (latching or non-latching).
    - Fire Alarm disconnect input options:
      - a) Normally open (NO) or normally closed (NC) dry contact input.
      - b) Polarity reversal from FACP output circuit.
    - Fire Alarm disconnect options:
      - a) Eight (8) outputs affected.
      - b) Four (4) outputs affected, four (4) outputs unaffected (50/50 mode).
  - Alarm output relay indicates that FACP input is triggered (form "C" contact rated @ 1 amp 28VDC not evaluated by UL).
  - Green LED indicates when FACP disconnect is triggered.
  - Built-in charger for sealed lead acid or gel type batteries.
  - Maximum charge current .7 amps.
  - Automatic switch over to stand-by battery when AC fails.
  - Zero voltage drop when unit switches over to battery backup (AC failure condition).
  - Thermal and short circuit protection with auto reset.
  - AC input and DC output LED indicators.
  - AC fail supervision (form "C" contact).
  - Battery fail and battery presence supervision (form "C" contact).
  - Enclosure accommodates up to two (2) 12AH batteries.
  - Removable terminal blocks facilitate ease of installation.
  - Unit is complete with enclosure, cam lock, transformer and battery leads.
- Enclosure dimensions: 15.5"H x 12"W x 4.5"D



## Installation Instructions:

The AL400ULACM should be installed in accordance with The National Electrical Code and all applicable Local Regulations.

1. Mount the AL400ULACM in desired location. It is recommended to first review the following tables for screw terminals, switch selection and LED status indications. This will greatly facilitate installation hook-up.

### Carefully review:

<i>Voltage Output Settings</i>	<i>(pg. 6)</i>	<i>Terminal Identification Tables</i>	<i>(pgs. 4 &amp; 5)</i>
<i>Stand-by Specifications</i>	<i>(pg. 6)</i>	<i>Typical Application Diagram</i>	<i>(pg. 5)</i>
<i>LED Diagnostics</i>	<i>(pg. 4)</i>	<i>Hook-up Diagrams</i>	<i>(pg. 7)</i>

2. **Setting output voltage (Fig. 2, pg. 6):**

Set AL400ULACM to the desired DC output voltage by setting switch SW1 to the appropriate position (refer to voltage output settings).

**Note:** It is important to measure voltage before connecting devices. This helps avoid potential damage.

3. **Connecting AC input voltage (Fig. 2, pg. 6):**

Connect unswitched AC power (115VAC 50/60Hz) to terminals marked [L, G, N]. Use 18 AWG or larger for all power connections. Secure green wire lead to earth ground.

**Keep power limited wiring separate from non-power limited wiring (115VAC / 60Hz Input, Battery Wires).**

**Minimum .25" spacing must be provided.**

4. **Output options (Fig. 1, pg. 5):**

The AL400ULACM will provide either eight (8) powered (switched and/or auxiliary), eight (8) form "C", or any combination of both powered and form "C" outputs.

#### (a) Switched Power outputs:

Connect the negative (-) input of the device being powered to the terminal marked [COM]. For fail-safe operation connect the positive (+) input of the device being powered to the terminal marked [NC]. For fail-secure operation connect the positive (+) input of the device being powered to the terminal marked [NO].

#### (b) Form "C" outputs:

When form "C" outputs are desired the corresponding output fuse (1-8) must be removed. Connect negative (-) of the power supply directly to the locking device. Connect the positive (+) of the power supply to the terminal marked [C]. For fail-safe operation connect the positive (+) of the device being powered to the terminal marked [NC]. For fail-secure operation connect the positive (+) of the device being powered to the terminal marked [NO].

#### (c) Auxiliary Power outputs (unswitched):

Connect positive (+) input of the device being powered to the terminal marked [C] and the negative (-) of the device being powered to the terminal marked [COM]. This output can be used to provide power for card readers, keypads etc.

5. **Input trigger options (Fig. 1, pg. 5):**

#### (a) Normally Open [NO] input trigger:

Inputs 1-8 are activated by normally open or open collector sink inputs.

Connect devices (card readers, keypads, request to exit buttons etc.) to terminals marked [IN] and [GND].

#### (b) Open Collector Sink inputs:

Connect the access control panel open collector sink positive (+) to the terminal marked [IN] and the negative (-) to the terminal marked [GND].

6. **Fire Alarm Interface options (Figs. 4 thru 8, pg. 7):**

A normally closed [NC], normally open [NO] or reversal of polarity input from a fire alarm control panel (FACP) will trigger all outputs, except when the 50/50 mode option is selected.

**50/50 output mode:** (Four (4) outputs with FACP disconnect with and four (4) outputs without FACP disconnect)

To program the 50/50 mode set switch SW1 to the closed position. In this mode of operation outputs 1 thru 4 will be affected when the fire alarm interface is triggered and outputs 5 thru 8 will remain unaffected.

#### (a) Normally Open [NO] input:

Connect the normally open FACP trigger input to the terminals marked [+ INP] and [T].

#### (b) Normally Closed [NC] input:

Connect the normally closed FACP trigger input to the terminals marked [+ INP -] and install a jumper across the terminals marked [+ INP] and [T].

#### (c) Output Circuit input trigger:

Connect the positive (+) and negative (-) from the FACP output circuit to the terminals marked [+ INP -].

Connect the FACP EOL to the terminals marked [+ RET -] (polarity is referenced in an alarm condition).

**Jumper J3 must be cut (fig. 4, pg. 7).**

7. **FACP dry contact output:**

Connect desired device to be triggered by the AL400ULACM's dry contact output to the terminals marked [NO] and [C] FACP for normally open output or the terminals marked [NC] and [C] FACP for normally closed output.

8. **Battery connections (Fig. 2, pg. 6):**

**For Access Control applications batteries are optional. When batteries are not used a loss of AC will result in the loss of output voltage.** Batteries must be lead acid or gel type. Connect one (1) 12VDC battery to the terminals marked [+ BAT -] for 12VDC operation. Use two (2) 12VDC batteries wired in series for 24VDC operation.

9. **Supervisory relay output (Fig. 2 , pg. 6):**

It is required to connect supervisory trouble reporting devices to outputs marked [AC FAIL, BAT FAIL] and [Power Fail] supervisory relay outputs marked [NC, C, NO] to appropriate notification devices. Use 22 AWG to 18 AWG for AC Fail & Low/No Battery reporting. Cut “AC delay” jumper to delay report 6 hour. **A tamper switch must be installed and connected to the appropriate notification device to report a trouble condition when the enclosure door is open.**

10. **Multiple power supply inputs (Fig. 1, pg. 5 & Fig. 3, pg. 7):**

When the use of two power supplies is desired, **jumper J1 and J2** (located to the left of the power/control terminals) **must be cut**. Connect power for the ACM8 to the terminals marked [- Control +] and connect power for the locking devices to the terminals marked [- Power +]. When using DC power supplies polarity must be observed. When using AC power supplies polarity need not be observed.

**Note: For UL compliance the additional power supply must be power limited, UL Listed for Access Control Systems and accessories.**

**Maintenance:**

Unit should be tested at least once a year for the proper operation as follows:

Output Voltage Test: Under normal load conditions, the DC output voltage should be checked for proper voltage level (see power supply output specifications table).

Battery Test: Under normal load conditions check that the battery is fully charged, check specified voltage at the battery terminals and at the board terminals marked [- BAT +] to insure that there is no break in the battery connection wires.

**Note:** Maximum charge current under discharge is .7 amps.

Expected battery life is 5 years, however it is recommended to change batteries within 4 years or less if necessary.

For UL Listed burglar alarm applications, this unit can be used to power UL Listed intrusion devices and residential bells.

**This unit may not be used to power a mercantile bell.**

**LED Diagnostics:**

**AL400ULXB - Power Supply**

LED		Power Supply Status
Red (DC)	Green (AC)	
ON	ON	Normal operating condition.
ON	OFF	Loss of AC, Stand-by battery supplying power.
OFF	ON	No DC output. Short circuit or thermal overload condition.
OFF	OFF	No DC output. Loss of AC. Discharged battery.

**ACM8 - Access Power Controller**

LED	ON	OFF
LED 1- LED 8 (Red)	Output relay(s) energized.	Output relay(s) de-energized.
Trg (Green)	FACP input triggered (alarm condition).	FACP normal (non-alarm condition).

**Terminal Identification Table:**

**AL400ULXB - Power Supply**

Terminal Legend	Function/Description
L, G, N	Connect 115 VAC 50/60Hz to these terminals: L to hot, N to neutral, G to ground.
+ DC -	Provides 12VDC @ 4 amps or 24VDC @ 3 amps to ACM8 board.
AC FAIL C, NC, NO	Used to notify loss of AC power, e.g. connect to audible device or alarm panel. Relay normally energized when AC power is present. Contact rating 1 amp @ 28VDC. AC or brownout fail is reported within 1 minute of event. To delay reporting of up to 6 hrs., cut “AC delay” jumper and reset power to unit.
BAT FAIL NO, NC, C	Used to indicate low battery condition, e.g. connect to alarm panel. Relay normally energized when DC power is present. Contact rating 1 amp @ 28VDC. A removed battery is reported within 5 minutes. Battery reconnection is reported within 1 minute. Low battery threshold: 12VDC output threshold set @ approximately 10.5VDC, 24VDC output threshold set @ approximately 21VDC.
- BAT +	Stand-by battery connections. Maximum charge rate .7 amp.

**Terminal Identification Table:  
ACM8 - Access Power Controller**

Terminal Legend	Function/Description
- Power +	12VDC or 24 VDC input from AL400ULXB.
- Control +	These terminals can be connected to a separate power limited, UL listed power supply to provide isolated operating power for the ACM8 (jumpers J1 and J2 Must be removed).
TRIGGER INPUT 1- INPUT 8 IN,GND	From normally open and/or open collector sink trigger inputs (request to exit buttons, exit pir's, etc.).
OUTPUT 1-OUTPUT 8 NC, C, NO, COM	12 to 24 volts AC/DC trigger controlled outputs: Fail-safe [NC positive (+) & COM Negative (-)], Fail-secure [NO positive (+) & COM Negative (-)], Auxiliary output [C positive (+) & COM Negative (-)] (When using AC power supplies polarity need not be observed), NC, C, NO become form "C" 5 amp 24 VAC/VDC rated dry outputs when fuses are removed. Contacts shown in a non-triggered state.
FACP INTERFACE T, + INPUT -	Fire Alarm Interface trigger input from FACP. Trigger inputs can be normally open, normally closed from an FACP output circuit. (Fig. 4 thru 8 , pg. 7)
FACP INTERFACE NC, C, NO	Form "C" relay contact rated @ 1 amp 28VDC for alarm reporting. (This output has not been evaluated by UL).

**Typical Application Diagram:**

**Fig. 1**

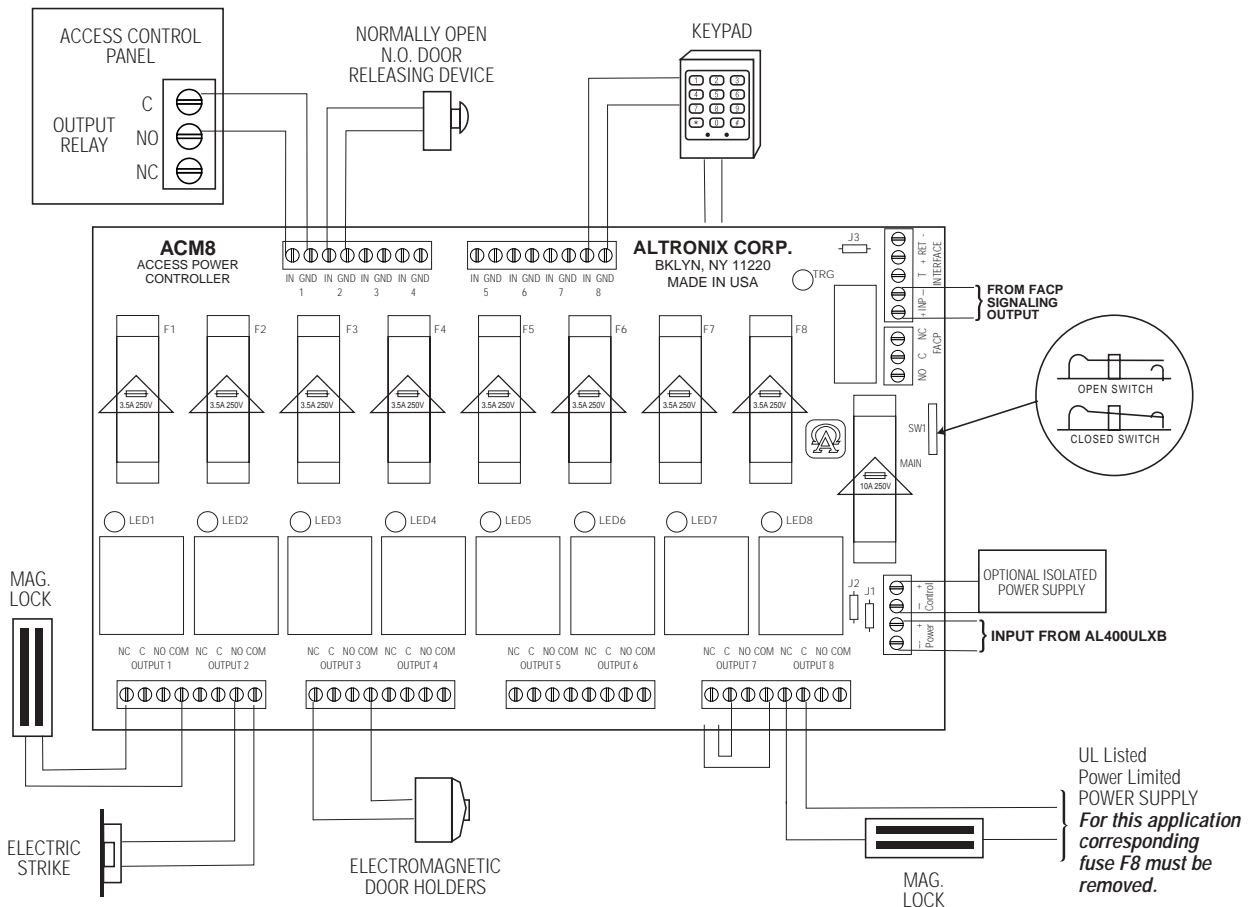

**Voltage Output Settings:**  
**AL400ULXB - Power Supply**

Output	Switch Position
12VDC	SW 1 Closed
24VDC	SW 1 Open

**Stand-by Specifications:**

Output	4 hr. of Stand-by & 5 Minutes of Alarm	24 hr. of Stand-by & 5 Minutes of Alarm
12VDC / 40 AH Battery	Stand-by = 3.5 amps Alarm = 3.5 amps	Stand-by = .5 amps Alarm = 3.5 amps
24VDC / 40 AH Battery	Stand-by = 2.75 amps Alarm = 2.75 amps	Stand-by = .75 amps Alarm = 2.75 amps

**Fig. 2**

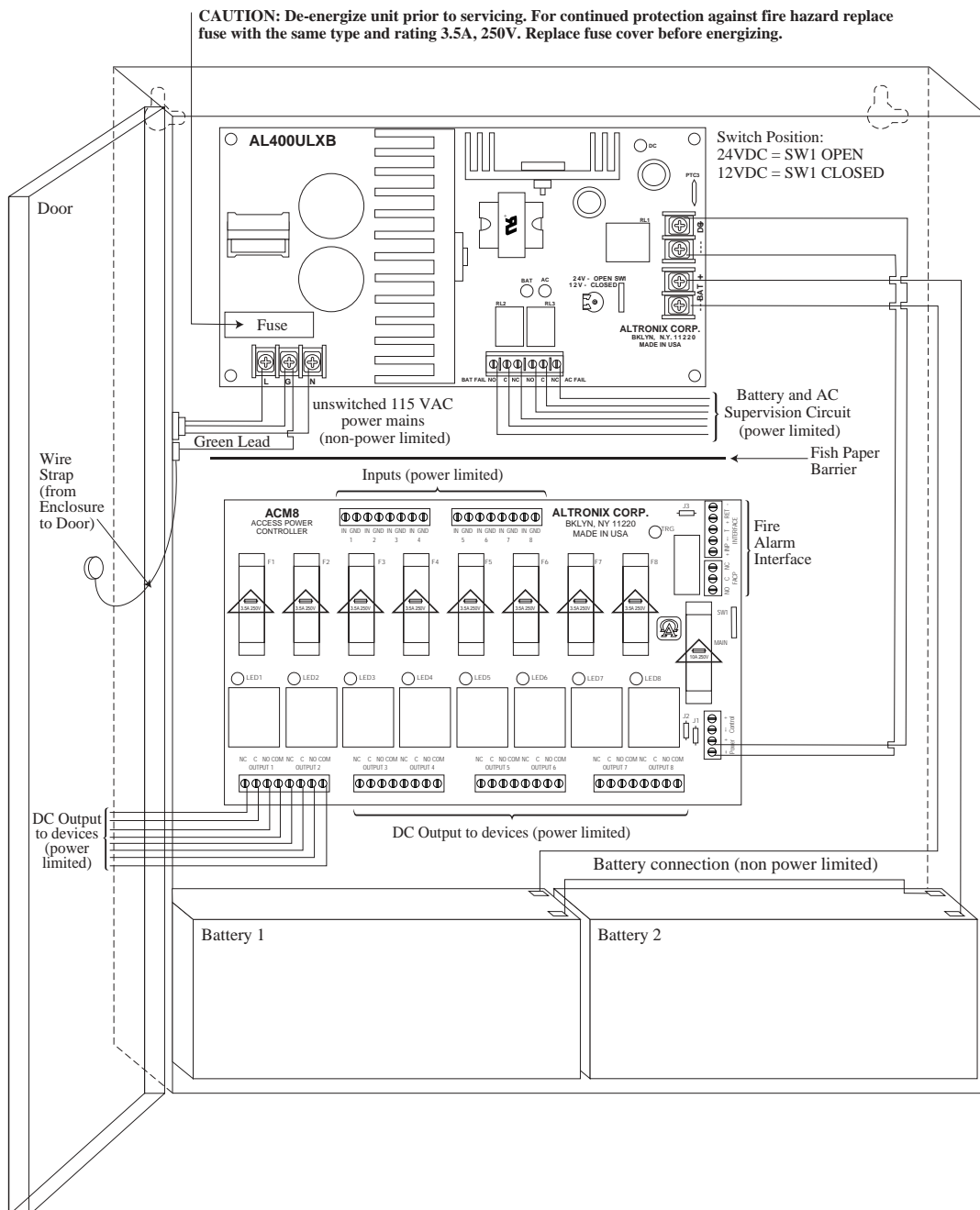

**Hook-up Diagrams:**

**Fig. 3** Optional hook-up using two (2) isolated power inputs:

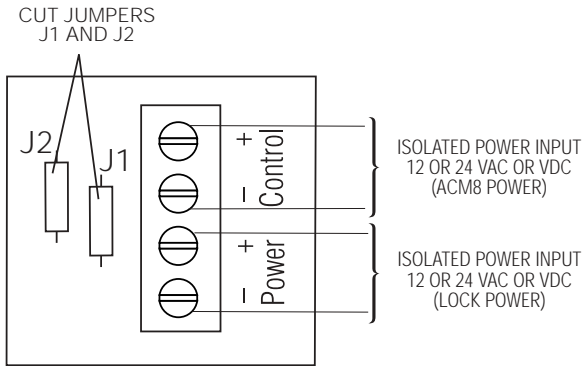

**Fig. 4** Polarity reversal input from FACP output circuit (polarity is referenced in alarm condition):

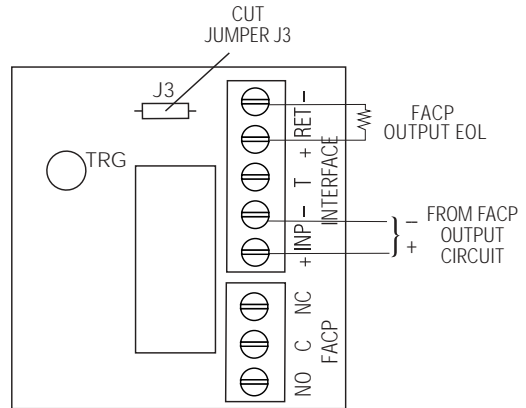

**Fig. 5** Normally Open Non-Latching FACP trigger input:

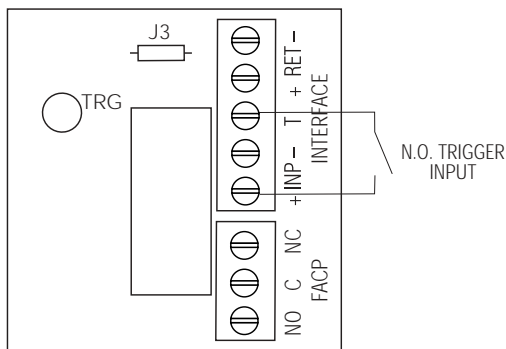

**Fig. 6** Normally Open FACP Latching trigger input with reset: (This output has not been evaluated by UL)

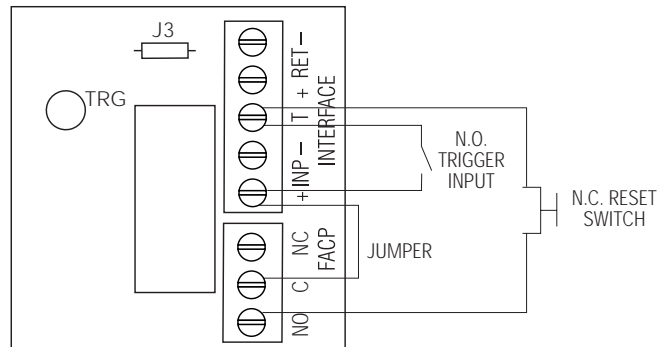

**Fig. 7** Normally Closed Non-Latching FACP trigger input:

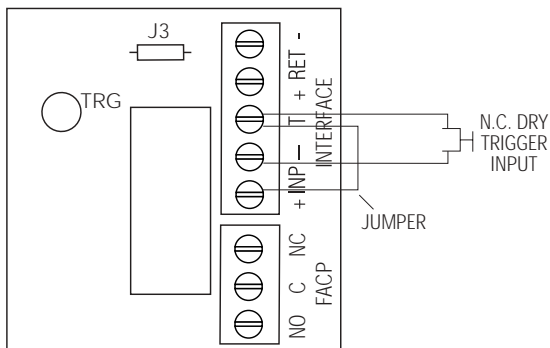

**Fig. 8** Normally Closed Latching FACP trigger input with reset: (This output has not been evaluated by UL)

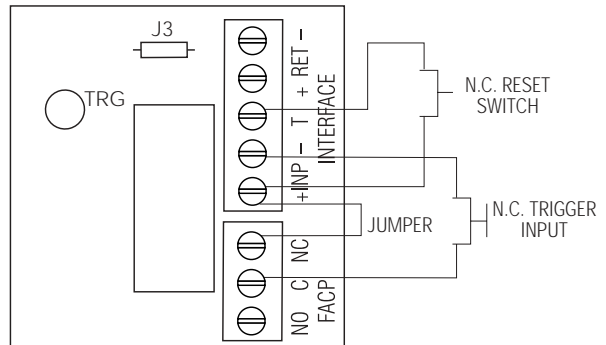

**Enclosure Dimensions:**

15.5"H x 12"W x 4.5"D

